



MODERN BULK MERCHANDISING SOLUTIONS



SELLING BULK FOOD HAS NEVER BEEN EASIER!





OUR COMPANY

For over 10 years, Rosseto has been helping industry leaders both large and small find solutions for their businesses.

New BULKShop from Rosseto is Revolutionizing Bulk Merchandising. Now anyone can assemble a complete standalone retail display. No specialists required. We have set the standard in the industry for quality and design and BULKShop is no exception. Each product is made with the best materials available and is crafted for commercial and high traffic use.

Choose from a range of pre-packaged Gondola and Shelving kits to get started. Know exactly what you want? No problem, you can build a custom unit with dispenser sets, scoop bins and more! We also offer pre-made Marketing Graphics kits with themes like Natural Foods and Trail Mix. You can use your own logo and graphics too! Just send us the complete file from your graphic designer and we will have them printed and added to your order.

*Start selling the day you receive
your Bulkshop package!*

We also have the BULKShop Shelving System for businesses that are short on space and already have Lozier or Madix shelving in place. The BULKShop Shelving System allows you to create a custom display with dispensers, scoop bins and graphics kits that mount onto your existing standard shelving.

Let us help you find a solution for your business! Give us a call to talk to one of our BULKShop experts.

Patent numbers: © Rosseto 2016, products are covered by one or more USA & International patents: 6,964,355, 7,703, 639 B2, D507,9336 S, D616,707 SD613, 558 SD531, 457 S371513-0001,D500, 636 S,D604,106 S and Other USA and International patents pending.

THE BEST BULK RETAIL SOLUTION AVAILABLE

BENEFITS

- ✓ **Most value** for your money (big footprint with a small investment)
- ✓ Free ingredient label templates
- ✓ No labor or installation costs
- ✓ **4 Easy Cleaning Steps**
- ✓ **NSF, BPA & FDA approved**

MODULAR, VERSATILE DESIGN

- ✓ Competitors require a design team to come and measure, then they build a huge custom wooden shelving system you can't move or change.
- ✓ Bulkshop Gondola is modular and easy to assemble by 2 people, no design team required. Then if you want to move it or change from candy to natural foods- no problem.
- ✓ Bulkshop Gondola stands alone and does not need to be bolted to the floor.

PORTION CONTROL TECHNOLOGY

- ✓ Competitors use levers you have to pull down to release product which makes a mess and doesn't control portions.
- ✓ Bulkshop dispensers allow you to "dial in" exact portions, letting you control food cost, reduce waste and SAVE money.



Our portion control technology removes product waste associated with pull levers. Simply turn the dial to get the exact portion you need every time.

ENVIRONMENTALLY RESPONSIBLE DESIGN

We make it easy to be green! Our modular design and portion control technology reduces waste and provides the simplest way to add a bulk foods section to your business.

ROSSETO IS ECO FRIENDLY

All of our containers and dispenser wheel are FDA approved, BPA Free and available in NSF options.



NSF certification is your key to making sure that the products you use meet strict standards for public health protection.



FDA approval means the agency has determined that the benefits of the product outweigh the risks for the intended use.



BPA Free products are made with plastics that contain no Bisphenol A, which may be harmful.



Our Patented Silicon wheel allows you to get precise portions every time, without crushing your product. It is also food safe and easy to clean.

WHY BULK?



35%

Warehouse Club Members' Savings

89%

Organic Bulk Food Savings Compared to Prepackaged Products

- Warehouse club members' save 35% on prepackaged goods compared to buying the same products at conventional grocery stores.
- Organic bulk foods on average cost 89% less than their packaged counterparts. (add a little 1 for footnote).
- With bulk, customers pay for exactly what they need, not extra product or packaging.

76%

Customers That Feel Recycling Is Important

52%

Customers That Think Food Has Too Much Wasted Packaging

- If Americans purchased all of their coffee in bulk for one year, 240 million pounds of foil packaging would be saved from our landfills. ⁸
- Less manufacturing of packaging means less carbon footprint overall.



78%

Customers state that having the ability to buy exactly what they need when they shop is a big advantage

- Bulk displays encourage incremental purchases because it is easy and affordable for customers to try new products in small doses.
- Portion control dispensers actively engage customers in their shopping experience.
- Rosseto BulkShop system solutions allows for multiple points of customer navigation, making it easy for the customer to identify the products they need (gluten free, sugar free, nut free).

Retailer Advantages



- BulkShop gondola systems provide a turnkey solution for integration of new products- no need to wait for category reviews or resets!
- Want to test a new flavor or assortment with your customers? It's easy to do with Bulk- Simply swap out the product in the dispenser or scoop bin.



54%

Average Retailer Savings

- Retailers save an average of 54% on material, product and delivery cost when moving to bulk because more product fits on their trucks.
- Portion control reduces waste/shrink.
- Bulk foods carry 40%-50% profit margins

- Bulk candy's US retail market size exceeds \$2 billion. ⁴
- Bulk is growing 15% per year according to the Bulk Is Green Council.
- more than 11% of total supermarket candy sales in the US! ⁵
- New displays can increase sales 25-35%.
- Bulk Bins Highlighted as a #1 Trending Store Improvement in 2013. ⁶

- Dispensers are easy to refill and clean- they break down in 3 steps, saving time and labor!
- First in, first out (fif) system means products are always fresh.

Sources - 1,7,8 Portland State University's Food Industry Leadership Center (FILC) on behalf of The Bulk is Green Council (BIG) - Food Waste Reduction Alliance - According to Natural Foods Merchandiser Magazine - Category Handbook by Confectioner Magazine - Bulk Is Green Council - Natural Foods Merchandiser

THE BULKSHOP GONDOLA SYSTEM

Our BULKshop Gondola System is Rosseto's own modern gondola design.

Perfect as a standalone unit, or easily connected to other gondolas, the BULKshop Gondola System was designed to make it easy for you to create a beautiful, sustainable bulk foods solution, whether for an incremental display or entire store. Featuring Rosseto's patented portioncontrol dispensers, innovative catch trays, multiple branding options and customizable design, the BULKshop Gondola System is going to take your products and store to new heights.

- ✔ Strong and sturdy
- ✔ Perfect as a stand-alone solution
- ✔ Gondola easily connects back-to-back or side-by-side to other BULKshop Gondolas



Perfect as a stand alone display, or easily connects back-to-back or side-by-side with other BULKshop Gondolas

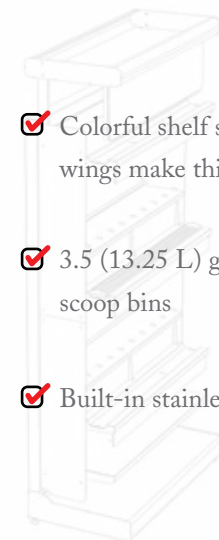

- ✔ Colorful shelf strips, catch tray backings and wings make this display stand out
- ✔ 3.5 (13.25 L) gallon BULKshop dispensers & scoop bins
- ✔ Built-in stainless steel catch trays, reduces mess



- ✔ Header creates additional height and space for advertising/messaging
- ✔ Metal and advertising made in the USA
- ✔ Attach bins to a bracket, or lay flat on the shelf

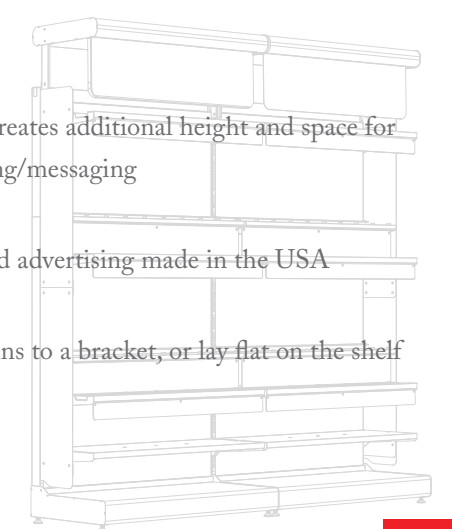

GONDOLA EZ INSTALL KIT OPTIONS:



Kit A

BULKshop Gondola 67" - 170.18 cm, (2) Rows of Dispensers (18) with (2) Mounting Shelves and (2) Catch Tray Shelves, (2) Catch Tray Backings, (2) Shelf Strips, (2) 67" - 170.18 cm Wings

Item # GK201 - Coffee

Item # GK202 - Candy

Item # GK203 - Natural Foods



Kit B

BULKshop Gondola 67" - 170.18 cm, (1) Row of Dispensers (9) with Mounting Shelf and Catch Tray Shelf, (3) Rows of Scoop Bins (18), 2" - 5.08 cm Scoop Bin Bracket, 4" - 10.16 cm Scoop Bin Bracket, 6" - 15.24 cm Scoop Bin Bracket, (1) Catch Tray Backing, (1) Shelf Strip, (2) 67" - 170.18 cm Wings

Item # GK211 - Coffee

Item # GK212 - Candy

Item # GK213 - Natural Foods



ADD SCOOP BINS
TO YOUR ORDER



Kit C

BULKshop Gondola 108" - 274.32 cm

Roof Kit with Advertising

(2) Rows of Dispensers (18) with

(2) Mounting Shelves and

(3) Catch Trays

(6) Scoop Bins

4" - 10.16 cm Scoop Bin Bracket

(2) Catch Tray Backings

(3) Shelf Strips

(2) 95" - 241.3 cm Wings

Item # GK101 - Coffee

Item # GK102 - Candy

Item # GK103 - Natural Foods



Kit D

BULKshop Gondola 108" - 274.32 cm

Roof Kit with Advertising

(2) Rows of Dispensers (18) with

(2) Mounting Shelves and

(2) Catch Tray Shelves

(1) Flat Shelf

(2) Catch Tray Backings

(2) Shelf Strips

(2) 95" - 241.3 cm Wings

Item # GK111 - Coffee

Item # GK111- Candy

Item # GK113- Natural Foods



SEE OUR GONDOLAS IN ACTION

Our customers are already making the BULKstore Gondala System their own. With all the versatility and opportunities to customize, you too can find a solution that is best for you and your business.



CREATE A CUSTOM BULK SOLUTION THAT WORKS WITH YOUR STORE DESIGN



Rosseto has been an industry leader for 10 years



THE BULKSHOP SHELF SYSTEM

Our BULKshop Shelf System connects to your existing Madix and Lozier gondola shelving systems.

Featuring Rosseto's patented portion-control dispensers, innovative catch trays and customizable branding options, the BULKshop Shelf System was thoughtfully designed to help reduce food waste and labor and, ultimately, increase sales.

MAKE IT EASY

Our EZ Install Kits make installation fast and efficient! We've put everything together for you - dispensers, catch trays and beautiful sign kits. No long lead times, no waiting. Order your EZ Install Kit today and have your new bulk foods section next week!

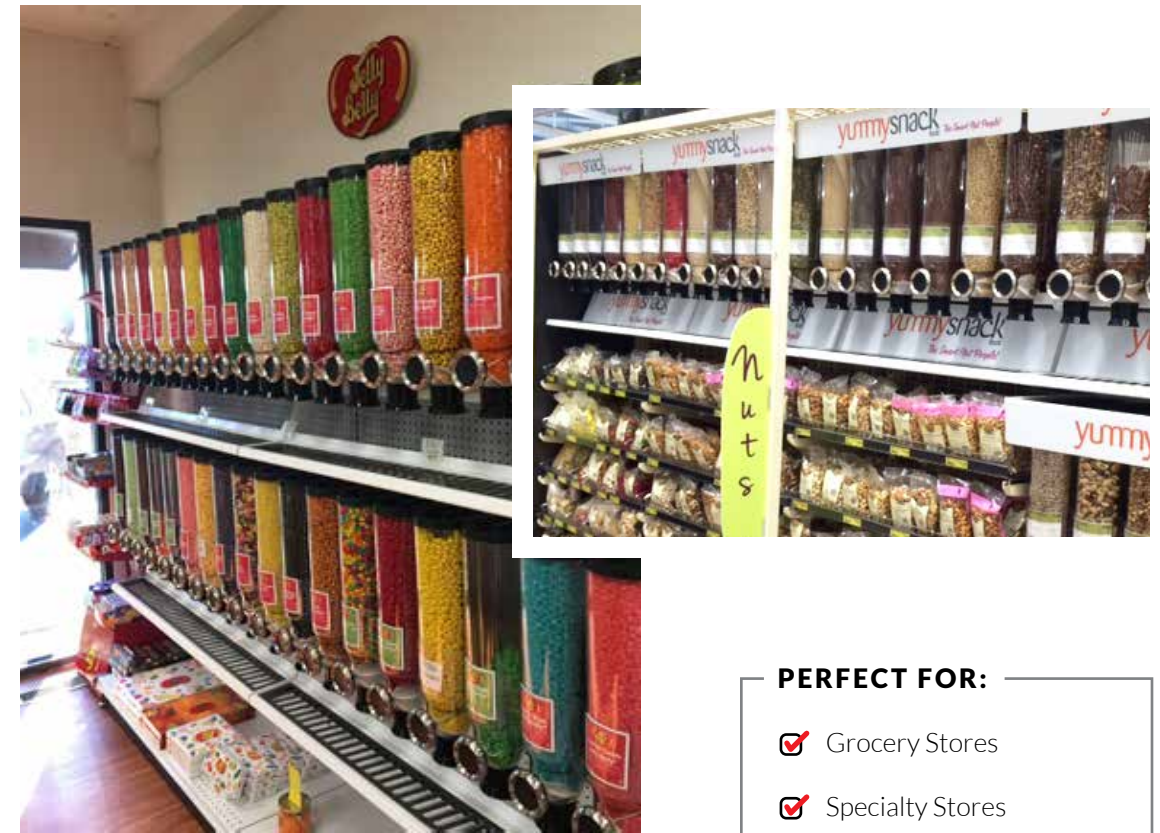

PERFECT FOR:

- Grocery Stores
- Specialty Stores
- Bulk Food Manufacturers



Metal and advertising made in the USA

3.5 gallon (13.25 L) BULKshop dispensers

Colorful shelf strips, catch tray backings and wings make this display stand out

Built-in stainless steel catch trays, reduces mess



FUNCTIONALITY AND STYLE FOR YOUR BULK FOODS SECTION

Choose From 3 Different Shelving Kit Options!

With a variety of addons and extras, Rosseto delivers the perfect shelving dispenser kit for any space. Shelf headers, catch trays and professionally designed graphic options add style and functionality to your dispenser experience.

The Dispenser

Each of our shelf kits comes with our modern 3.5 gallon (13.25 L) dispensers. Durability has never looked this good.



Header and Catch Tray Graphics

Make your shelf kit stand out with one of our shelf kit options that include graphics.

Natural



Coffee



Candy



Basic Shelf Kit #SD3100

Includes:
9 DS101 with Mounting Shelf

*Does not include catch tray



Premium Shelf Kit with Graphics #SD3200

Includes:
9 DS101, Shelf, Catch Tray, Shelf Header, Header Graphics, Catch Tray Graphics

Available in:
Coffee #SD3211
Candy #SD3221
Natural Foods #SD3231



Standard Shelf Kit with Graphics #SD3000

Includes:
9 DS101, Shelf, Catch Tray, Catch Tray Graphics

Available in:
Coffee #SD3011
Candy #SD3021
Natural Foods #SD3031

*Does not include header

THE BULKSHOP DISPENSER

Included with the BULKshop Shelf System and the BULKshop Gondola System

- ✓ 3.5 gallon (13.25 L) acrylic container
- ✓ Solid metal knob with extra branding option
- ✓ Lid
- ✓ Transparent false front chamber
- ✓ Removable sign holder
- ✓ 1.5 oz. patented portion control wheel
- ✓ Easy grip funnel for clean dispensing
- ✓ Knob branding/consumer navigation piece
- ✓ False-front chamber easy refill funnel
- ✓ 4 easy cleaning steps



Proud to Provide Certified Products



Dispenser
 5.1 x 16.5 x 17.5 in
 12.9 x 41.9 x 44.4 cm
 3.5 gal / 13.3 L
Item # DS101

- False Front Chamber - Always Looks Full
- Removable Label Holder
- Extra Branding Option



- EZ to Operate 3.5 Gallon / 13.3 Liter Container
- Fits any Gondola Shelving System
- Shelf Mount
- EZ Grip Funnel

- PERFECT FOR:**
- ✓ Retail Stores
 - ✓ College Campuses
 - ✓ Break Rooms
 - ✓ Counter-top Displays

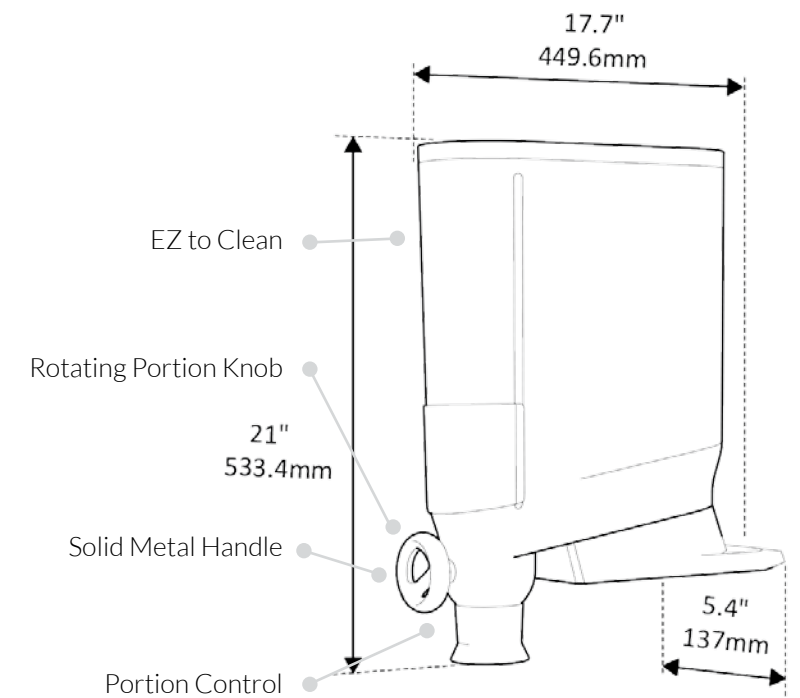

SHELF MOUNTING KITS

Already have your own custom shelving? No problem! We have designed a special Shelf Mounting Strip that allows you to mount our Bulkshop Dispenser # DS101 on virtually any pre-existing shelving unit.

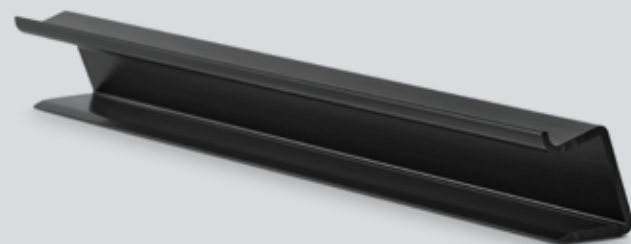

Available in 4 different size options

- 0.9ft (265mm) Shelf Mounting Strip - #DSM265
- 1.3 ft (400mm) Shelf Mounting Strip - #DSM400
- 3ft (900mm) Shelf Mounting Strip - #DSM900
- 4ft (1209mm) Shelf Mounting Strip - #DSM1209

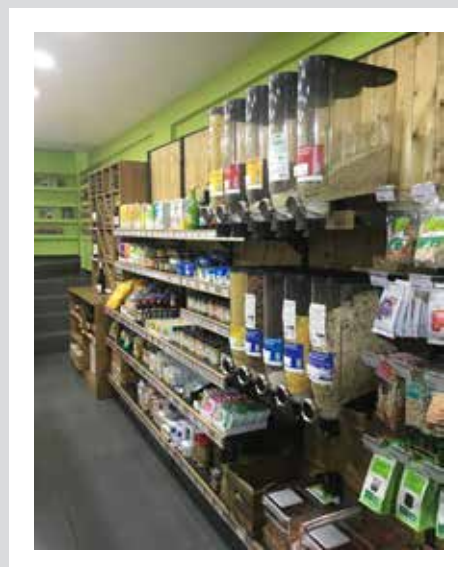

ACCESSORIES

Customize your Bulkshop Gondola or Shelf System with these convenient accessories.

Pro Bulk® Bag Holder

Offer bulk shopping bags without sacrificing style with the new Pro Bulk Bag holder stand.

This single acrylic unit includes three distinct sections of space and a FREE label holder.

11.97 x 5.31 x 17.56 in
30.4 x 13.5 x 44.6 cm

Item # DS107



- ✓ Convenient bag storage for your Bulk food display
- ✓ Easy to remove and fill
- ✓ Includes a FREE label option for additional advertising
- ✓ Made of high-quality acrylic



Acrylic Plastic Scoop (1 each)

9.6 x 3.5 x 1.5 in
24.4 x 8.9 x 3.8 cm
Available in Charcoal Gray and Clear



Item # GDM002



Acrylic Tong (1 each)

9 x 5 x 1 in
22.9 x 3.8 x 2.5 cm
Available in Charcoal Gray and Clear



Item # GDM006



Scoop Bins

3.5 Gal / 15.4 L ea.
7.8 x 17 x 12.3 in
19.8 x 43.1 x 31.2 cm

Item # SA126



BRANDING & CUSTOMER NAVIGATION

The BULKshop solutions have been strategically designed to offer multiple points of customer navigation, including various advertising and branding options, sign holders and optional label customization.



Make it easy for customers to navigate through your selection.

Free inside knob labels and ingredient labels allow you to clearly mark items like Gluten Free, Sugar Free and more!



We offer FREE label templates! We will send you the template so you can easily design your own professional ingredient label.



EZ-PRO® WALL MOUNTED DISPENSERS



EZ-PRO™ 5W

1 Gal / 3.8 L ea.
26 x 7.75 x 15 in
66 x 19.7 x 38.1 cm

Item # EZP2890

Item # EZPRO5W-N



EZ-PRO™ 1W

1 Gal / 3.8 L
7 x 7.75 x 15 in
17.8 x 12.7 x 45.7 cm

Item # EZ501

Item # EZPRO1W-N



EZ-PRO™ 3W

1 Gal / 3.8 L ea.
15.5 x 7.75 x 15 in
39.4 x 19.7 x 38.1 cm

Item # EZP2906

Item # EZPRO3W-N

3W Catch Tray

Stainless Steel
17.8 x 8 x 1.5 in
45.2 x 20.3 x 3.8 cm

Item # EZT017



5W Catch Tray

Stainless Steel
29 x 8 x 1.5 in
73.7 x 20.3 x 3.8 cm

Item # EZT016



All wall mounted EZ-SERV® and EZ-PRO™ dispensers receive 6 different sized portion wheels in each container.

 NSF Certified options available. Please call for more information.





EZ-SERV® WALL MOUNTED DISPENSERS



EZ-SERV® 1W

1.3 Gal / 4.94 L
6 x 6.5 x 21 in
15.2 x 16.5 x 53.3 cm

Item # EZ523



Wall Mount EZ-SERV® Dispenser

Single, 2 Gal / 7.6 L
8.5 x 9 x 24 in
21.6 x 22.9 x 61 cm

Item # EZ538



EZ-SERV® 3W

1.3 Gal. / 4.94 L ea.
17.8 x 6.5 x 21 in
45.2 x 16.5 x 53.3 cm

Item # EZ525



EZ-SERV® 5W

1.3 Ga / 4.94 L ea.
29 x 6.5 x 21 in
73.7 x 16.5 x 53.3 cm

Item # EZ527



EZ-SERV® 5SW

0.65 Gal / 2.47 L ea.
29 x 7 x 15.25 in
73.7 x 17.8 x 38.7 cm

Item # EZ534



EZ-SERV® 2W

1.3 Gal / 4.94 L ea.
12 x 6.5 x 21 in
30.5 x 16.5 x 53.3 cm

Item # EZ524



Wall Mount XL EZ-SERV® Dispenser

Single, 3.5 Gal / 13.3 L
8.5 x 21 x 28 in
21.6 x 22.9 x 61 cm

Item # EZ540



EZ-SERV® 3SW

0.65 Gal / 2.47 L ea.
17.8 x 7 x 15.25 in
45.2 x 17.8 x 38.7 cm

Item # EZ533



3W Catch Tray

Stainless Steel
17.8 x 8 x 1.5 in
45.2 x 20.3 x 3.8 cm

Item # EZT017



5W Catch Tray

Stainless Steel
29 x 8 x 1.5 in
73.7 x 20.3 x 3.8 cm

Item # EZT016



All wall mounted EZ-SERV® and EZ-PRO™ dispensers receive 6 different sized portion wheels in each container.

 NSF Certified options available. Please call for more information.

BULK shop™



rosseto 
SERVING SOLUTIONS

www.rosseto.com

847.763.1215

info@rosseto.com

